

# Low Volume Spring Developments

B.K. Northup, D.T. Goerend, D.M. Hays, and R.A. Nicholson

Reduced federal and state cost-share funds for conservation practices plus higher costs have necessitated the need for less costly range improvements. Though traditional methods of spring development are not as expensive as some stockwater systems, substantial cost reductions for all developments are desirable. A low-cost alternative to the traditional spring development designs used by the Soil Conservation Service (SCS) has been utilized in Kansas to develop sites with low volume springs or seeps that require three collection lines or less. Expense is reduced by elimination of the traditional spring box (Soil Conservation Service 1982).

## Construction Methods

The traditional design (Fig. 1) that meets Kansas SCS specifications for federal cost-share funds consists of: collection system of perforated plastic pipe, metal spring box with lid and foundation, delivery line of pvc pipe, stock tank, and pvc pipe outlet. The collection system, delivery line, and outlet pipes are installed in the bottom of a trench dug by backhoe to the proper grade. The trench for the collection system should extend far enough below the seep area to intercept flow and permit the collection of water. A filter of clean gravel encloses the collection system, and a retainer wall is constructed at the downstream end of the perforated pipe. The spring box is constructed of durable materials with inlet and outlet pipes at least six inches above its floor to trap sediments and allow air to escape the delivery line. Delivery lines and outlet pipes must be installed with a slope that allows air to escape from the system and water to fill the tank. The trench is backfilled after the installation of all pipe, gravel filter, and retainer wall. The site for the stock tank is leveled and the design includes measures to protect the development from trampling and other hazards, such as freezing.

An alternative system, developed in 1980, removes the spring box from the design and utilizes less costly components (Fig. 2). A four-inch pvc pipe with a vented cap is used as a riser and positioned at the junction of the collection line(s). Additionally, a brass flush valve, housed in a covered meter box for protection and access, is installed in the delivery line 30 to 40 feet beyond the inlet pipe of the tank. Overflow from the tank is routed to the outlet pipe beyond the flush valve. The vented riser allows air to escape the system and permits the clearing of airlocks. The pipe between the inlet of the tank and flush valve acts as a settling basin, and sediments are removed from the system by opening the flush valve and allowing the water in the system to eliminate sediments by gravity.

The riser-flush valve system differs greatly from the many traditional designs used (Evans 1960, Secrist 1981, Soil Conservation Service 1982). Although removal of the spring box might increase problems with operation and maintenance, components that replace it function adequately and provide certain advantages, if properly maintained. Lower investment cost is a major advantage of the riser-flush valve system. Traditional designs are applicable to any spring site regardless of yield, but higher costs per unit of output will be incurred if used on low volume or intermittent sites.

In Saline County, Kansas, installation costs of riser-flush valve developments were 10.8 percent less than the traditional system used by SCS. The average cost of materials, from 1981-85, to construct the spring box and riser-flush valve components was \$240 and \$90, respectively. Total cost of spring developments was reduced from \$1,389 to \$1,239 (Table 1).

**Table 1. Comparative costs of riser-flush valve and traditional spring developments.**

Components	Costs	
	Spring box	Riser-Flush Valve
<b>Comparable Components</b>		
Pipe, Fittings, Etc.	\$231	\$231
Backhoe & Incidental Machinery	387	387
Gravel, Rip-Rap	199	199
Stock Tank	164	164
Labor	80	80
Mileage & Delivery Costs	88	88
<b>Subtotal Comparable Components</b>	<b>\$1149</b>	<b>\$1149</b>
<b>Spring box Components</b>		
Conduit (spring box w/lid)	\$198	---
Concrete (spring box foundation)	\$42	---
<b>Subtotal Spring box Components</b>	<b>\$240</b>	
<b>Riser-Flush Valve Components</b>		
Meterbox and Lid	---	\$37
Vent & Flush Valve Components (riser & cap, pipe, flush valve, tee, reducers, etc.)	---	\$53
<b>Subtotal Riser-Flush Valve Components</b>		<b>\$90</b>
<b>Total Costs</b>	<b>\$1389</b>	<b>\$1239</b>

Labor required for routine maintenance of riser-flush valve systems consists of a few minutes required to flush the delivery line periodically. This can be done as part of the scheduled visits required to manage livestock grazing the land unit. The system design allows airlocks to be cleared easily. Most can be cleared by a "purge" of water through the delivery line by operating the flush valve. However, if uniform grade for the delivery line was not maintained during construction, airlocks will occur regularly, as in traditional designs. Lack of proper maintenance can cause the delivery line to become partially or totally plugged with sediment, resulting in reduced water yield or expensive maintenance. The requirement for periodic maintenance might limit use of this design on sites that are difficult to visit regularly, although design of the system could be modified to increase the storage area for sediments.

If the riser-flush valve system is to function properly, three elements must be controlled: (1) system designs must ensure sufficient vertical drop through the system for loss of head pressure and to allow water to fill the tank; (2) during construction, a uniform grade must be maintained for the delivery line; and (3) the flush valve must be opened periodically to clear the systems of sediment (Soil Conservation Service 1982).

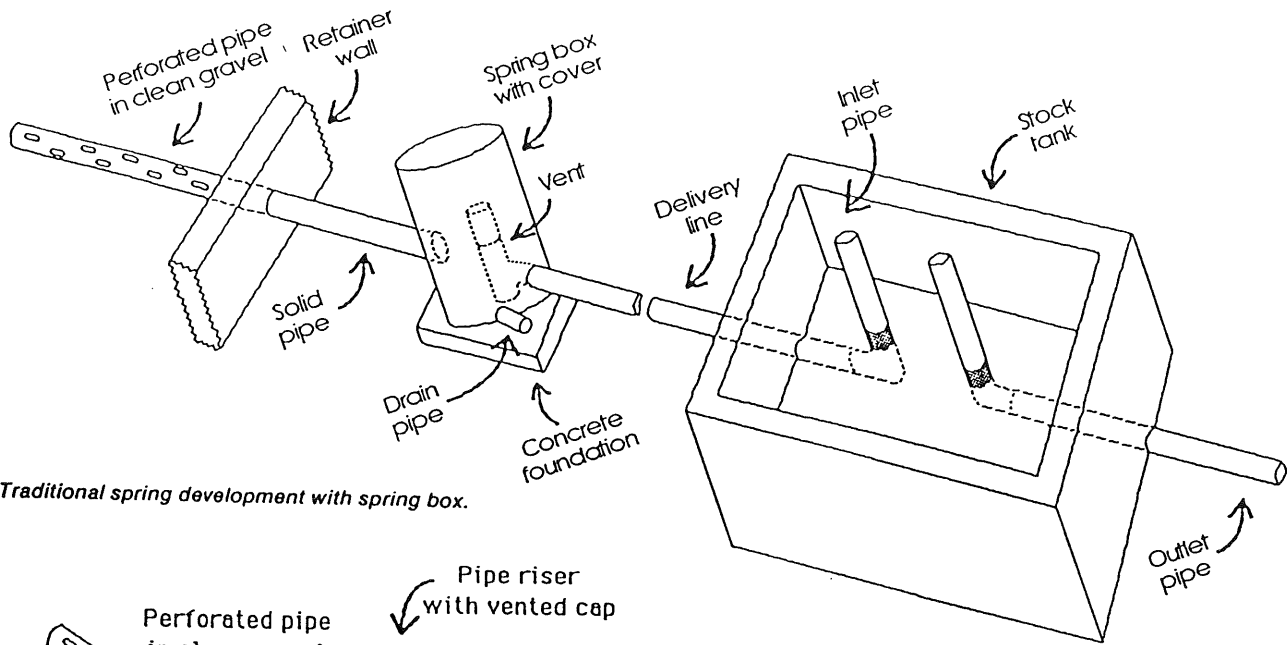

Fig. 1. Traditional spring development with spring box.

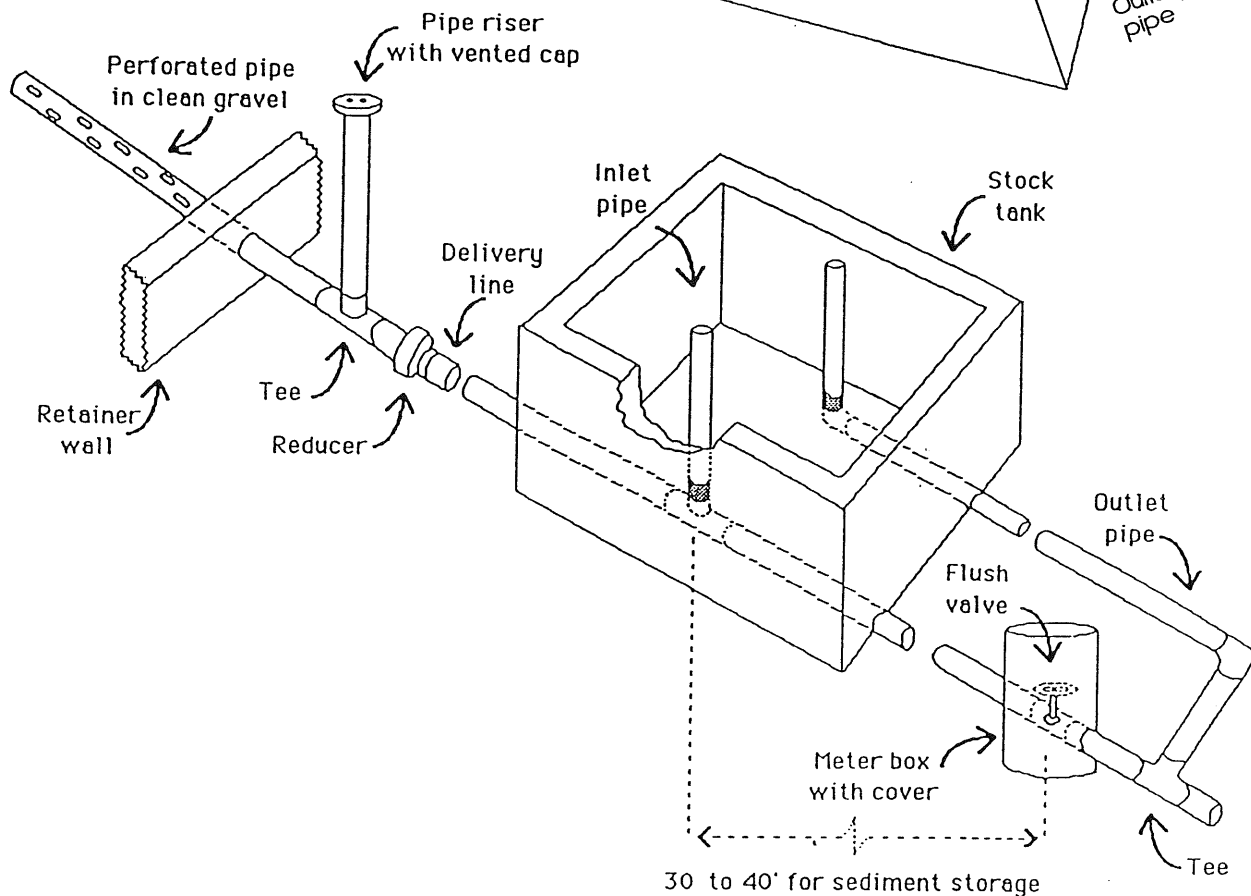

Fig. 2. Spring development with vented riser and flush valve.

Riser-flush valve systems have been used extensively in Saline County, Kansas, on contact or depression-type spring sites with output rates as high as 5 gpm after development. Reduction in costs and effectiveness of the design have largely eliminated use of traditional systems on low volume sites. From 1981-85, 34 riser-flush valve systems were constructed, compared to three spring box systems; no spring box systems have been constructed since 1981. Lower cost of installation and ease of maintenance make this system desirable, where management schedules allow, for use on low volume or intermittent spring or seep sites that requires three or fewer collection lines.

### Literature Cited

- Evans, H.O. 1960. Spring development for stockwater. *Texas Agric. Prog.* 6:9-10.
- Secrist, G.M. 1978. Techniques for developing springs for livestock on western rangelands. *Soc. Range Manage., Abstract of Papers* 31:17.
- Soil Conservation Service. 1982. Kansas standard for spring development-574. *In: Kansas Technical Guide, Note KS-97, USDA-SCS.*

Authors are graduate assistant, Department of Biological Sciences, Fort Hays State University, Hays, Kansas 67601 and former soil conservationist, Saline County, Kansas, USDA-SCS; and district conservationist, and conservation technician, Saline County, Kansas, USDA-SCS; and professor of botany, Fort Hays State University.

Individuals interested in technical specifications should contact D.T. Goerend, District Conservationist, 1821 South Ohio, Salina, Kansas 67401.